



UNDERPINNERS

CS 88 & CS 89



FOOT-OPERATED



PNEUMATIC

Technical and User Manual

Version 2 au 12 / 06

CASSESE CARTRIDGE WEDGES

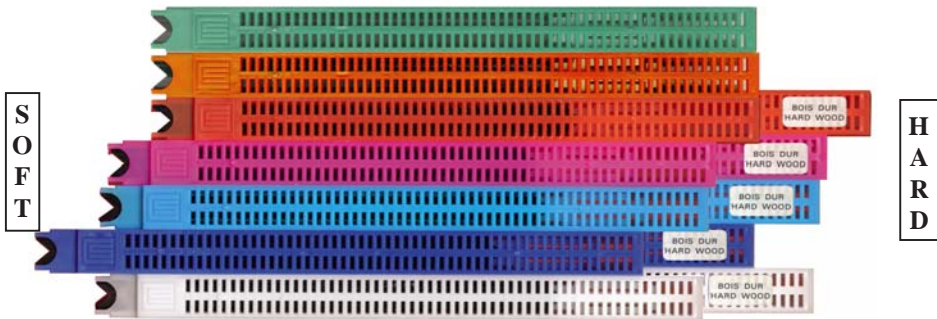

The joining is performed by using metal wedges, a Cassese invention, designed to ensure very tight corners.

Five standard sizes are available : 5, 7, 10, 12 and 15 mm.

On special request # 3 & 4 are available for slips (fillets).

They all come in throw-away cartridges that are colour-coded per size for easy identification.

Cartridge wedges exist in two versions :

NORMAL for soft and normal timbers and

HW for very hard timbers. *These hardwood wedges are to be used only on hardwoods.*

Your CS 88 - CS 89 is designed to use all sizes of Cassese cartridges without having to change any parts on the machine or having to adjust anything.

For the long term performance and reliability of your CS 88 - CS 89, only use genuine CASSESE wedge cartridges.

Beware of bad quality copies that would cause technical problems and would age your machine prematurely.

REFERENCE	TYPE
30303NCOI	3 mm
30304NCOI	4 mm
30305NCOI	5 mm
31305BDCO	5 mmBD
30307NCOI	7 mm
31307BDCO	7 mmBD
30310NCOI	10 mm
31310BDCO	10 mmBD
30312NCOI	12 mm
31312BDCO	12 mmBD
30315NCOI	15 mm
31315BDCO	15 mmBD

REFERENCE	TYPE
30403NCOI	3 mm
30404NCOI	4 mm
304 05 NCOI	5 mm
314 05 BDCO	5 mm BD
304 07 NCOI	7 mm
314 07 BDCO	7 mm BD
304 10 NCOI	10 mm
314 10 BDCO	10 mmBD
304 12 NCOI	12 mm
314 12 BDCO	12 mmBD
304 15 NCOI	15 mm
314 15 BDCO1	15 m

Boxes of 6 cartridges (app. 275 wedges)
(1650 wedges / box)

Boxes of 40 cartridges (app. 275 wedges)
(11000 wedges / box)

CONTENTS

PAGE N°

INTRODUCTION ACCESSORIES supplied with the machine: TECHNICAL SPECIFICATIONS OPTIONS WARRANTY	1
---	---

PUTTING INTO OPERATION

REASSEMBLY CS 89 AIR LINE FITTINGS	2-3
---------------------------------------	-----

ADJUSTMENTS

USE OF THE 2 SELF-ADJUSTING BACKFENCES	4
SELECTION OF STAPLING POSITIONS	4-5
SETTING AND STORING THE STAPLING POSITIONS	5
SELECTION OF A TOP PRESSER END / ADJUSTMENT OF THE ASSEMBLY ANGLE	6

USE

MEANS OF ASSEMBLY SETTING UP THE WEDGE CARTRIDGE UNDERPINNING THE FRAME	7-8
---	-----

MAINTENANCE

LUBRICATION CLEARING OF A WEDGE STUCK IN THE WEDGE DISTRIBUTOR	9
IN CASE OF HAMMER AND WEDGE JAMMING	10
CS 89 / SETTING THE LIMIT SCREW	11
TROUBLE SHOOTING	12

INTRODUCTION

You have just purchased a CS 88 / CS 89. We congratulate you on your excellent choice and we thank you for your trust.

The CS 88 / CS89 benefits from our long of experience in manufacturing frame assembly machines which have made us famous. It will assemble wooden mouldings of any profile (Patent n°8800188).

The CS 88 / CS89 is designed to permit operators to work in front of the machine or behind it. Assembly is by metal wedges designed specially to ensure perfect joining.

Use only wedges in cartridges manufactured by CASSESE® (CS trademark).

Beware of copies.

ACCESSORIES supplied with the machine:

- 3 allen wrenches (2.5 - 3 - 6),
- 1 replacement hammer,
- 1 white triangle (for soft woods),
- 1 black triangle for hard woods (mounted on machine) and its aluminium support,
- 1 tool for removing wedges from distribution head,
- 1 tube of grease
- 1 Spacer bars for small mouldings.

+(CS 89 only) 1 round rubber top presser (yellow for soft woods) + its aluminium support

+(CS 89 only) air supply fittings : 1 male connector (on machine) + 1 quick release female connector + 2 (1 standard + 1 US) hose connectors.

SPECIFICATIONS :

Minimum width of moulding	:	5 mm	maximum: 95 mm
Minimum height of moulding	:	5 mm	maximum: 85 mm
Minimum size of frame	:	60 x 60 mm (opening) -	
Size of wedges in cartridges of 275	:	3, 4, 5, 7, 10, 12, 15mm	
Two types of wedges for	:	soft wood, hard wood.	
Net weight	:	25 kg	
Dimensions	:	Width: 600 mm (24") Depth: 450 mm (18") Height: 1090 mm (43 1/2")	
(CS 89 only) Energy needed	:	Compressed air 6-7 bars (+/- 100 p.s.i.)	
(CS 89 only) air supply	:	air regulator + manometer, air tube to be used (inside diameter 8mm) for the standard connector.	

OPTIONS

Octagonal, hexagonal inserts or other to order. Other top pressers.

- 3 sockets to attach the machine to the floor:

*Insert the part D of the sockets into the holes of the feet
and then fix the sockets to the floor with a screw (not supplied).*

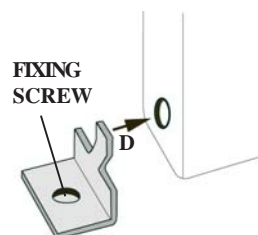

WARRANTY

CS 88 / CS89 is covered by a one year warranty for parts and labour and any manufacturing defects. Worn parts and parts damaged by use not in conformity with the terms of this manual are not covered by this warranty.

PUTTING INTO OPERATION

For safety during transportation, the moving parts of your CS 88 – 89 have been blocked : these are the Top Presser Bracket (or Plunger) / Sliding Table / Horizontal (rebate) Clamp.
 For the explanations given in this manual, the operator must be standing at the back of the machine, keeping the machine slightly in his left. (See REFERENCE POSITION below). In this position, the operator is always in the same distance to the corner, regardless of the size of the frame.

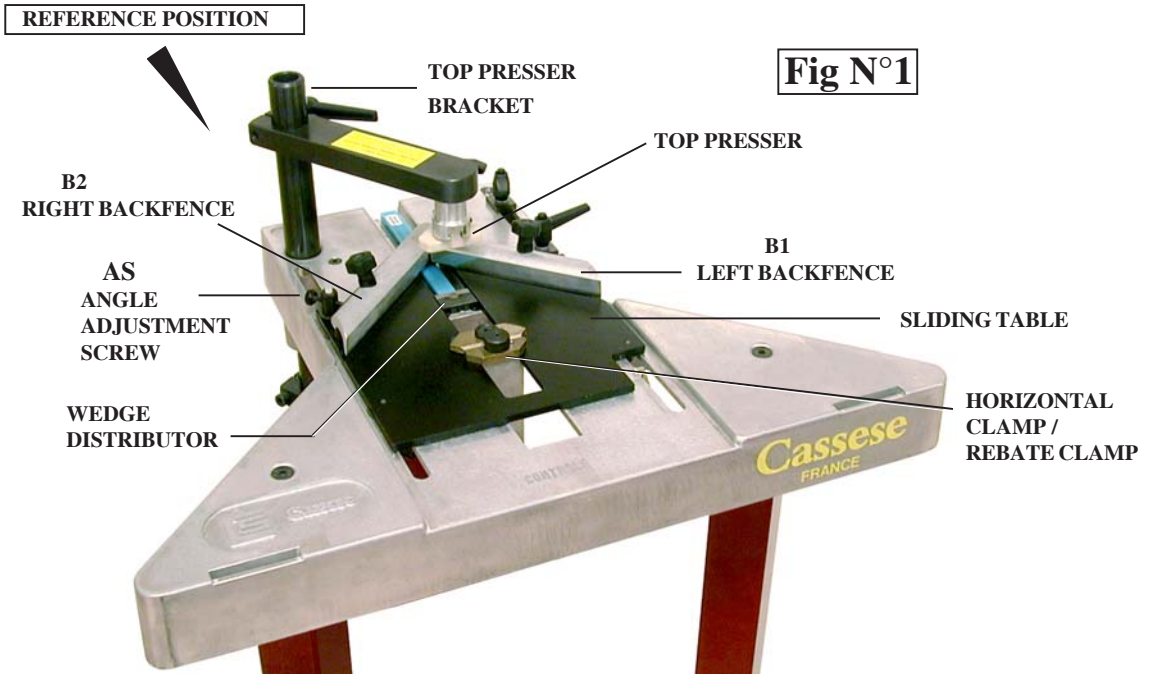

IMPORTANT : For the best, and most efficient function of your CS 88-89 machine, we advise you to carry out the adjustments exactly in the order of this manual.

**CS89 AIR CONNECTION
SEE PAGE 3**

Advice : to work frames of bigger sizes easily, you can put the CS 88-89 machines in front of your work bench (make sure that the work bench is not higher than the machine). The CS 88-89 machines have been conceived in a triangle form to fit any work bench : if you wish so, you can cut one of the corners of your work bench, to locate the machine in this corner. This way, while making big sized frames, you will not be using more than one of the corners of your work bench.

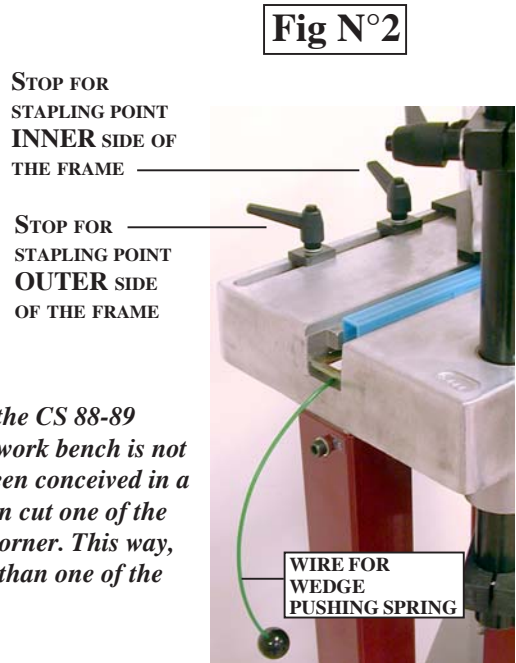

CS 89 AIR LINE FITTINGS

Advised way of fitting :



Z 675

USA

STANDARD

Male Connector
on Machine



Z 675



quick release (Q/R)
female air connector

Z 749



Q/R US male
connector

Z 701

Standard hose
connector

Z 556



AIR SOURCE (compressor)

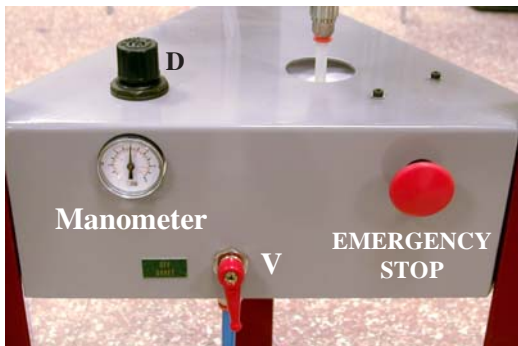

The CS 89 is to be connected to the air source under its lower grey plate, at the level of air valve V. Then turn the air valve V to ON. Make sure that the air pressure shown on the manometer is 6 bar (85 p.s.i.) otherwise correct it with the regulator D.

SETTINGS

USE OF THE 2 SELF-ADJUSTING BACKFENCES

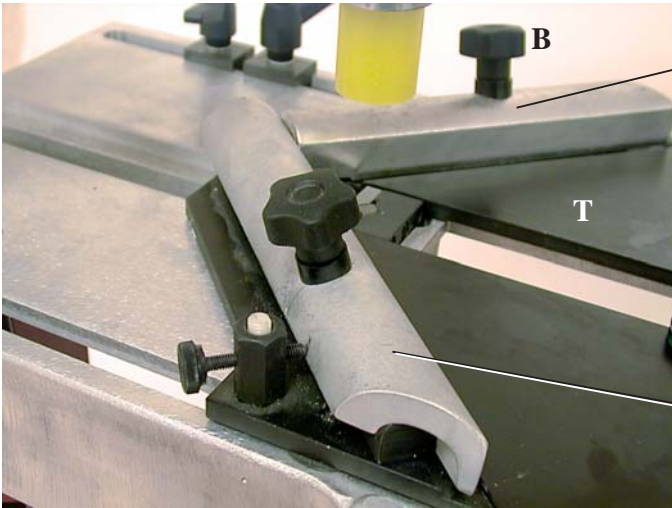

Position a moulding against the LEFT backfence.

Loosen the locking knob B.

Press the moulding against the table T, tilt the backfence so that it fits behind the moulding, then tighten knob B.

Position the second moulding on the RIGHT backfence and repeat the operation.

SELECTION OF STAPLING POSITIONS

The CS 88 / 89 is designed to join mouldings in one or two places (positions) without limitation of the number of wedges in any of those places. The selection depends on the width and thickness of the moulding to join.

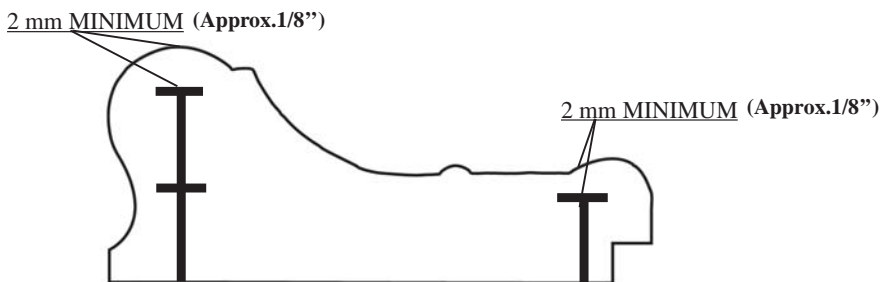

As a general rule a MINIMUM 2 mm clearance (less than 1/8") above the wedges shall be respected.

Same sized wedges can be stacked in order to avoid to have to change the cartridge size when joining frames with different thickness.

AS A GENERAL RULE, THE JOINING MUST BE CARRIED OUT AS CLOSE TO THE THICKEST MOULDING PART(S) AS POSSIBLE .

SETTING AND STORING THE STAPLING POSITIONS

Release the stapling positioning stops, P1 and P2.

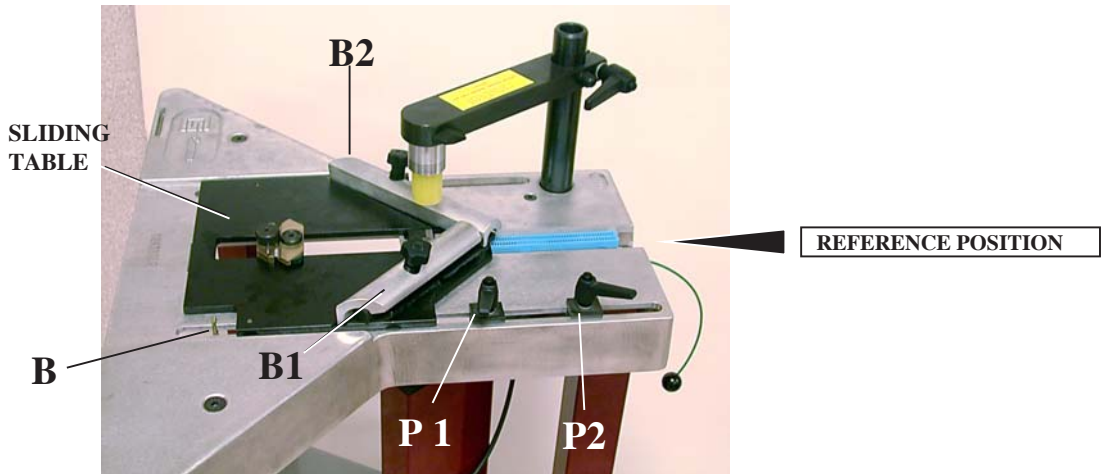

1) UNDERPINNING WITH 2 STAPLING POINTS

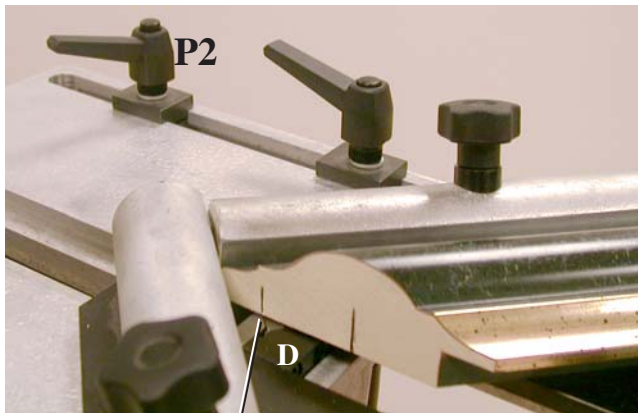

Position the first moulding against stop B1 and slide it up to stop B2.

First stapling position:

Outer side of the frame:

Move the sliding table forwards and align the wedge outlet of the distributor D with the required stapling position. Slide stop P2 (outer stapling stop) until its buffer comes into contact with the sliding table, then lock it.

WEDGE OUTLET

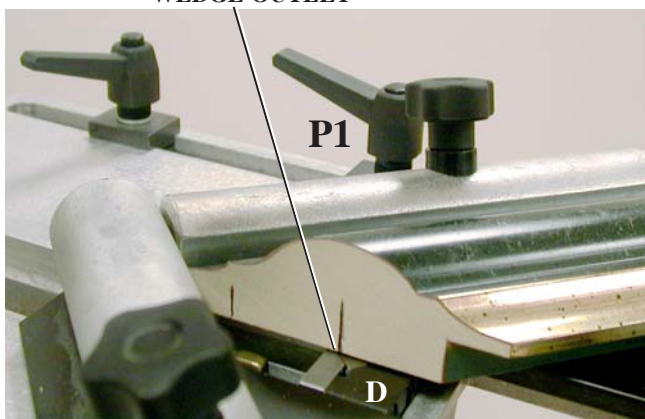

Second stapling position:

Inner side of the frame:

Move the sliding table backwards and align the wedge outlet of the distributor with the required stapling position. Slide stop P1 (inner stapling stop) against the sliding table, then lock it.

2) UNDERPINNING WITH 1 STAPLING POINT

Position the right moulding against the self-adjusting backfence. Move the sliding table so that the wedge outlet coincides with the required stapling point.

Lock the inner stapling stop P1. Then push the outer stapling stop P2 until its buffer B comes into contact with the sliding table, then lock it.

SELECTION OF A TOP PRESSER END

Make sure that the distance between the moulding's top and the presser's bottom is not more than _____

If the distance is bigger than this, use another (longer) top presser to reduce the distance.

CS88	CS89
35 mm MAXIMUM	50 mm MAXIMUM

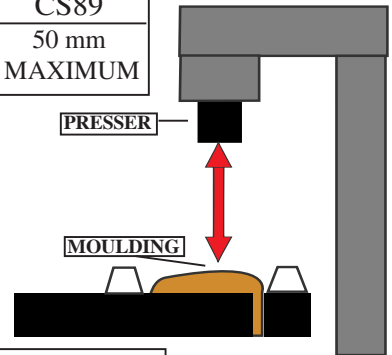

The triangle top pressers with their support that are included with your CS 88 / 89 give you the capacity to work mouldings up to 85 mm (1"½). For taller or complicated mouldings, there are other top pressers available from your regular source of Cassese products.

BLACK TRIANGLE PRESSER	FOR HARDWOODS	Fixing in support with 2.5 mm Allen key.
WHITE TRIANGLE PRESSER	FOR SOFT WOODS	
GREEN ROUND RUBBER ENDS	FOR HARDWOODS	1 long and 1 short
YELLOW ROUND RUBBER ENDS	FOR SOFT WOODS	1 long and 1 short

Triangle top pressers are good for flat mouldings or for mouldings representing a flat or horizontal area to come down on. The round rubber ends are good for complicated forms (uphill, downhill or reverse mouldings).

For very tall mouldings the round rubber ends can be also inserted into the top presser bracket without their support to gain capacity in height.

ADJUSTMENT OF THE ASSEMBLY ANGLE

If several cutting machines are being used in your production or if you receive your mouldings already cut by your suppliers (chop service), the angles of the mouldings will be slightly different from one cutting machine to the other. The joining angle of your CS 88 / CS 89 can be adapted to find precisely the cutting angle of your cutting machine.

If the corner is open towards outside, unscrew (turn anti-clockwise) the angle adjustment screw AS (see Fig 1 page 1) a little to correct the fault and check again.

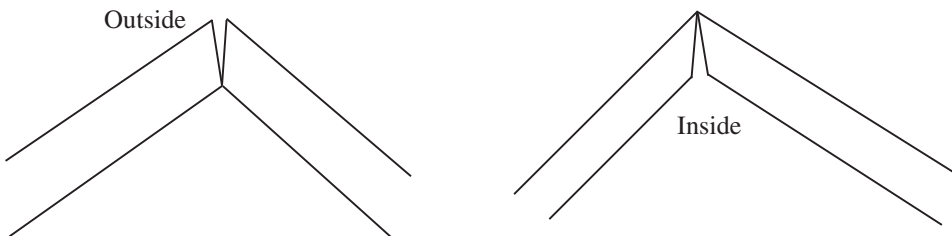

If the corner is open towards inside, screw in (turn clock-wise) the angle adjustment screw AS (Fig 1 page 1) to correct the fault.

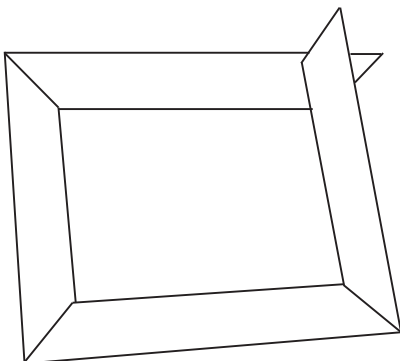

If you get this result, check your cutting angle, which is wrong in this case because it is less than 45°.

Carry out the adjustment of the angle of your cutting machine.

IT IS IMPOSSIBLE TO MAKE A RECTANGLE FRAME WITH ANGLES SMALLER THAN 90°.

USE

MEANS OF ASSEMBLY

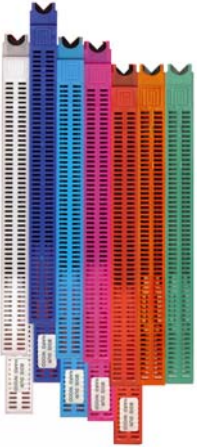

The joining is performed by using metal wedges, a Cassese invention, designed to ensure very tight corners. Seven sizes are available : 3, 4, 5, 7, 10, 12 and 15 mm. They come in throw-away cartridges that are colour-coded per size for easy identification. Cartridge wedges exist in two versions : NORMAL for soft and normal timbers and HW for very hard timbers. These hardwood wedges are to be used only on hardwoods. Your CS 88 / CS 89 machine is designed to use all sizes of Cassese cartridges without having to change any parts on the machine or having to adjust anything.

For the long term performance and reliability of your CS 88 / CS 89, only use genuine CASSESE cartridge wedges. Beware of counterfeit products.

SETTING UP THE WEDGE CARTRIDGE

Move the sliding table forwards to allow access to the cartridge. (1)

Pull the positioning cord back, using the ball as a grip. (2)

Push the cartridge fully home in the distributor slot. (3)

Release the wedge pusher cord carefully to avoid damaging the pusher and spring.

Note: For easier changing of the wedge magazine during operation, the wedge cartridge can be accessed by lifting the sliding table from the rear with the finger.

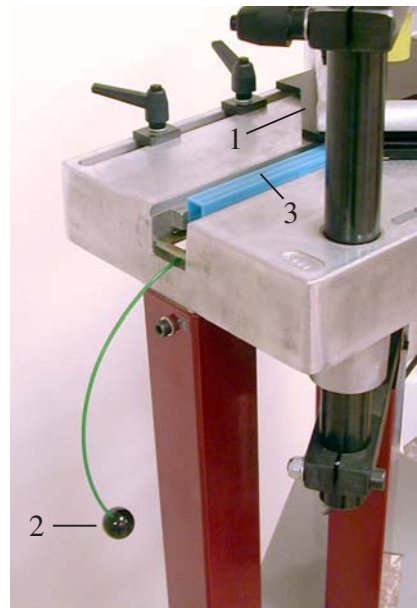

UNDERPINNING THE FRAME

The stapling points are defined (see Defining the stapling point, page 5).
The joint angle has been checked (see Setting the joint angle, page 6).
The distance between the top of the moulding and the bottom of the top clamp is outside permissible maximum. (See Choice of top presser, page 6).
Correct size wedges (normal wood or hard wood) have been loaded in the machine.

Position the first moulding against the right stop and slide it up to the left stop.

Keeping the first moulding secure, position the second moulding against the left stop, then slide it into contact with the first moulding.

Position the rebate clamp:

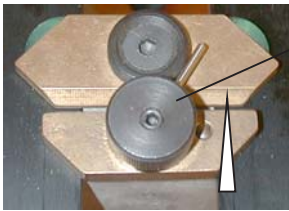

Unscrew the knob of the top clamp, then move the rebate clamp against the 2 mouldings, without forcing. Lock the rebate clamp knob again, without pushing it. Clearance of around 1 mm is left to make it easier to move the mouldings during assembly.

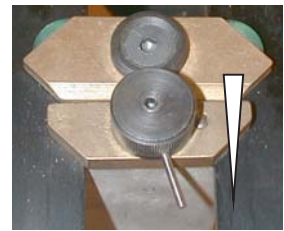

Move the sliding table forwards or backwards to stop P2 or P1 (page 5).

Then:

CS 88

Keeping the mouldings secure, slowly push down the pedal.

When the rebate clamp comes into contact with the moulding, speed up the movement so that the wedge is inserted more easily.

To stack wedges*

- Release the pedal until the top clamp begins to lift.
- Push the pedal down again.

* When stacking wedges, the sliding table should be locked in place.

CS 89

Keeping the moulding secure, gently push the pedal so that the two mouldings are secured by the rebate clamp.

Then press the pedal down fully to insert the wedge.

If there is a second stapling position, keep your foot pressing down on the pedal, move the sliding table to the second position, raise your foot slightly then push fully down to insert the second wedge.

Then release the pedal completely.

Note: If several wedges are inserted, raise your foot slightly to keep horizontal pressure on the mouldings, then push fully down: the second wedge is inserted and pushes the first wedge further in.

MAINTENANCE

1) LUBRICATION

Periodically, remove the wedge distributor (Fig 1, block H) and clean it (by air gun) without dismounting it.

It is recommended to lubricate the hammer (driver blade) periodically. To do so, remove the wedge distributor (block H) and put a small quantity of grease in the bottom hole of the wedge distributor. The hammer will be lubricated every time it crosses the wedge distributor.

2) CLEARING OF A WEDGE STUCK IN THE WEDGE DISTRIBUTOR

If you push the foot pedal half way and release, a wedge may be half engaged in the wedge distributor. In this case,

- Close the air valve (CS 89).
- Try to remove the cartridge that is in position. If it resists, use the wedge removal tool to push down the wedge back in the cartridge.
- Pay attention not to make penetrate the tool more than 6mm (1/4") into the wedge distributor.

It is important not to leave a wedge half engaged in the wedge distributor, as it may cause the insertion of two wedges when you join the next corner or may cause the jamming of the hammer (the driver blade) in the wedge distributor.

- In case of the hammer (driver blade) jamming with a wedge in the wedge distributor, see the following section (3).

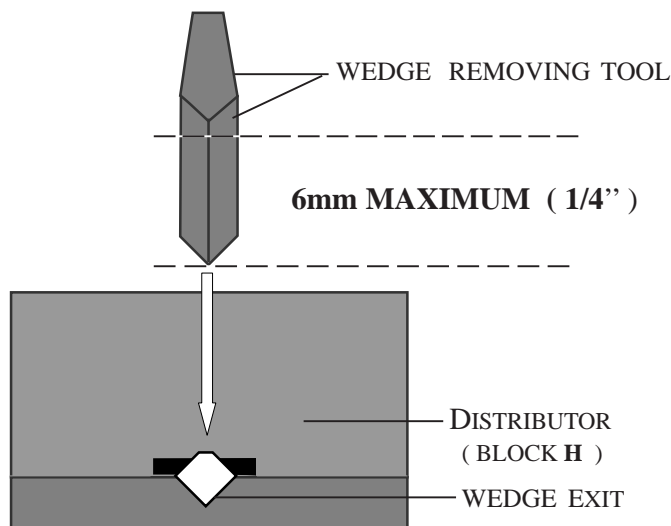

3) IN CASE OF HAMMER AND WEDGE JAMMING

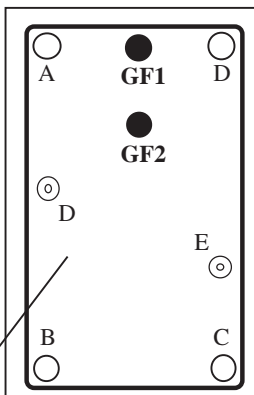
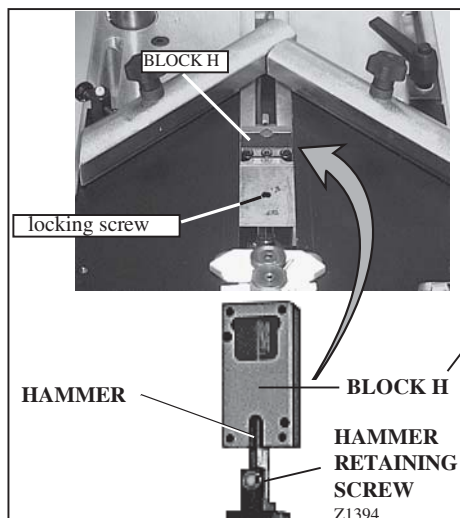

**BLOC H
SCREW POSITIONS**

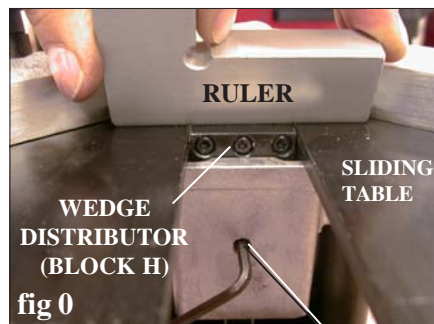

LOCKING SCREW

PROCEDURE

- Remove the cartridge that is on machine, and the top presser.
- Using the 3mm Allen key, loosen the locking screw of the wedge distributor **Block H**.
- Then lift the top presser's bracket arm by hand. The wedge distributor will come out of its housing. Remove it from the machine.
- The old hammer (wedge driver blade) is stuck in the wedge distributor : first try to remove it with a pair of pliers. If not possible, unscrew the two central screws (**GF1**, **GF2**) that hold the fixed (square) guide of **Block H** in place. Use for this the smaller (2.5mm) Allen key supplied with the machine. Remove the fixed guide completely to free the old hammer. If still not possible to get rid of the old hammer, remove the four screws (**A**, **B**, **C**, **D**) and open the **block H**.
- Remove the old hammer. Assemble the **Block H** back again.

Putting a new hammer (driver blade) :

- Put a drop of grease in the bottom hole of the wedge distributor (block H).
 - Insert a new hammer into block H with the hole of the hammer downwards.
 - Re-position the wedge distributor in its housing on the machine with the window towards the cartridge.
 - If the upper end of the hammer stays out of the block H, push it fully in with a piece of wood or moulding.
- While keeping the moulding in place (on block H) and pressing on it, pull up the top presser's bracket arm Po (Fig1 p1) with a quick movement.
- The new hammer must have taken its position in the mechanism automatically.
- Check with your finger or with a ruler that the **block H** does not stay out of the machine (higher than the work level) and tighten the locking screw of **block H**. No need to tighten too much.
 - The machine is ready to work again.

If you have any difficulty to remove the block H from the machine, push down with your hands the top presser's bracket arm. This should free the block H that is stuck with the hammer.

CS 89 SETTING THE LIMIT SCREW



WARNING!
ONLY CARRY OUT THIS
OPERATION IF IT IS
RECOMMENDED IN THE
TROUBLESHOOTING
REMEDIES AT THE END
OF THE MANUAL.

- 1) Take out the wedge cartridge.
- 2) Reduce the air pressure to 3 bars.
- 3) Set the plunger at less than 50 mm (2") from the table.
- 4) Holding nut E, turn the limit screw through 2 to 3 turns.
- 5) Press the pedal as if to start up stapling; as the limit detector is not actuated, the plunger remains in low position.
- 6) Unscrew the limit screw until the plunger moves upwards.
- 7) Once the plunger has lifted, unscrew the limit screw by an additional quarter turn.

TROUBLESHOOTING

IF THE PROPOSED REMEDIES DO NOT SOLVE THE PROBLEM CONTACT THE AFTER-SALES SERVICE

FAULT	POSSIBLE CAUSES	REMEDIES	
NO WEDGES ARE INSERTED INTO THE MOULDING	88-89 - The wedge cartridge is empty	- Fit a new wedge cartridge	
	88-89 - The wedge distributor is clogged	- Clean it	
	88-89 - The wedge spring is broken or relaxed	- Check the condition of the spring and replace if necessary	
	88-89 - The wedge driver blade is broken	- Change the wedge driver blade (page 10)	
THE WEDGE IS NOT FULLY INSERTED INTO THE MOULDING	88-89 - Top clamp / Moulding distance not within permissible maximum	- Reposition the plunger within permissible maximum distance (page 6)	
	88-89 - Moulding not adequately secured on the table	- Secure the moulding firmly on the table	
	88-89 - Wedge driver blade damaged	- Change the wedge driver blade	
	89 - Limit screw incorrectly set	- Check the setting of the limit screw	
	89 - Air supply pressure less than 6 bar	- Increase the pressure	
THE WEDGE BREAKS	88-89 - Hard wood	- Use hard wood wedges (page 7)	
ANGLE OFFSET	88-89 - The first moulding was not pushed firmly against the left stop (page 5)		
MOULDINGS DIFFICULT TO MOVE	88-89 - The rebate clamp is too tight against the mouldings.	- When the rebate clamp is tightened do not push it towards the mouldings	
STAINS ON BACK	88-89 - Too much grease on the wedge driver blade	- Clean the wedge driver blade	
POOR JOINING	- Corner open on inside	88-89 - Bad cut	- Repeat the cut
	- Corner open on outside	88-89 - Incorrect setting	- Loosen the AS screw (page 2-4) to compensate for opening
	- Opening on top and bottom of joint	88-89 - Incorrect setting of stops	- Check the self-adjusting backfences before starting underpinning
	- Mouldings marked by triangle rubber top pressor	88-89 - Triangle rubber top pressor for hard wood used on soft wood	- Use a suitable triangle rubber top pressor (page 6)
THE WEDGE DRIVER BLADE DOES NOT LOWER	88-89 - Misalignment	- Contact after-sales service	
THE PLUNGER DOES NOT LIFT	88-89 - Wedge jammed in the wedge distributor	- Dismantle the wedge driver blade to remove the wedge (page 10)	
	89 - Limit screw incorrectly set	- Reset the limit screw (page 11)	
	88-89 - Distance between bottom of top clamp and top of moulding outside permissible maximum	- Reposition the plunger and expel any wedge that may have gone into the wedge distributor using the tool supplied (page 9)	